

HIBM36S05-8 Balanced Mode Radiator

✓RoHS
COMPLIANT



Features

- Wide bandwidth and wide directivity
- 8Ω Impedance.
- Dimensions: 58.00mm x 58.00mm.
- Thickness: 20.60mm
- Mass: 65g

Applications

- Docking stations
- Table radios
- Sound bars
- Computer speakers

Description

The HIBM36S05-8 Balanced Mode Radiator (BMR) is an audio drive unit with an extended frequency response and wide directivity compared with a conventional drive unit. It combines the benefits of HiWave bending-wave technology and pistonic modes of operation. It is ideally suited for compact audio applications that require a full-range, high performance acoustic solution.

A 4 ohm version is also available.

Parameters

Parameter	Description	min	typ	max	Units
R_e	DC resistance	-10%	8.6	+10%	Ohms
L_e	Inductance (@ 10kHz)	-10%	0.11	+10%	mH
BW_A	Audio frequency range	100	-	20000	Hz
P	Power rating (IEC268-5)	-	-	5	W
BL	Force factor	-	3.5	-	Tm
f_s	Resonant frequency	-10%	176	+10%	Hz
SPL	Sound Pressure Level @ 1W, 1m	-	79	-	dB
dDrv	Voice coil diameter	-	25.4	-	mm
M_{ms}	Moving mass	-	2.0	-	g
C_{ms}	Compliance	-	0.42	-	mmN ⁻¹
R_{ms}	Suspension Loss	-	0.40	-	Nsm ⁻¹
X_{mech max}	Maximum coil excursion (p-p)	-	6.0	-	mm
Sd	Effective piston area	-	17.6	-	cm ²
V_{as}	Equivalent volume	-	0.177	-	L
Q_{ms}	Mechanical quality factor	-	5.54	-	
Q_{es}	Electrical quality factor	-	1.53	-	
Q_{ts}	Total quality factor	-	1.20	-	
Temp	Operating temperature range	-20	-	55	°C

Response

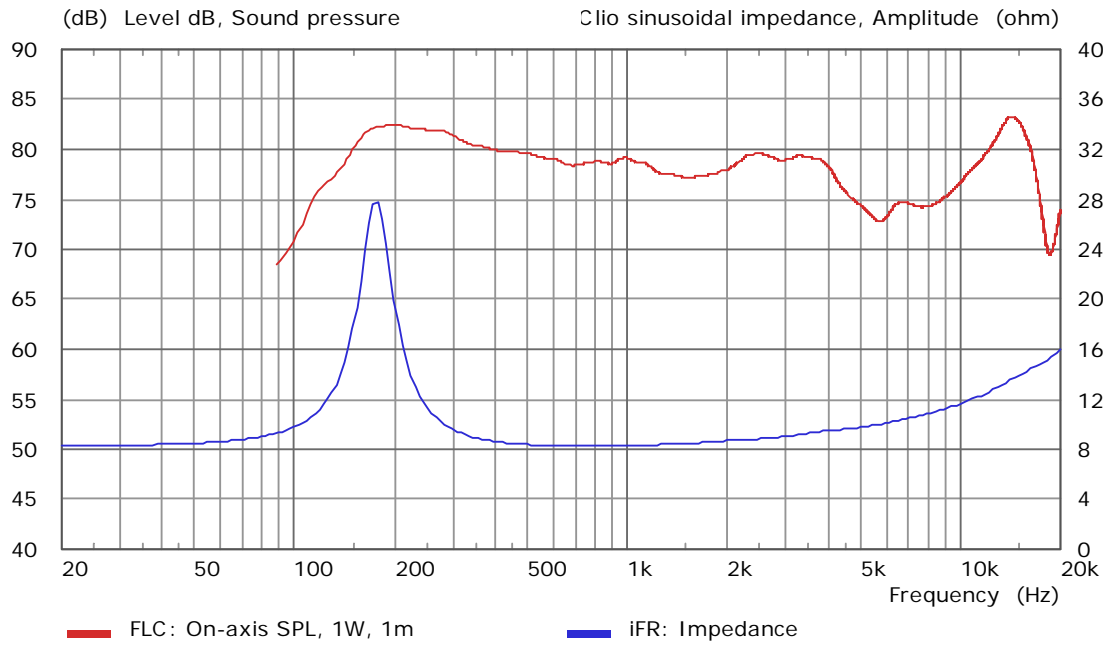

Figure 1. Impedance vs. frequency and SPL

Outline Drawing

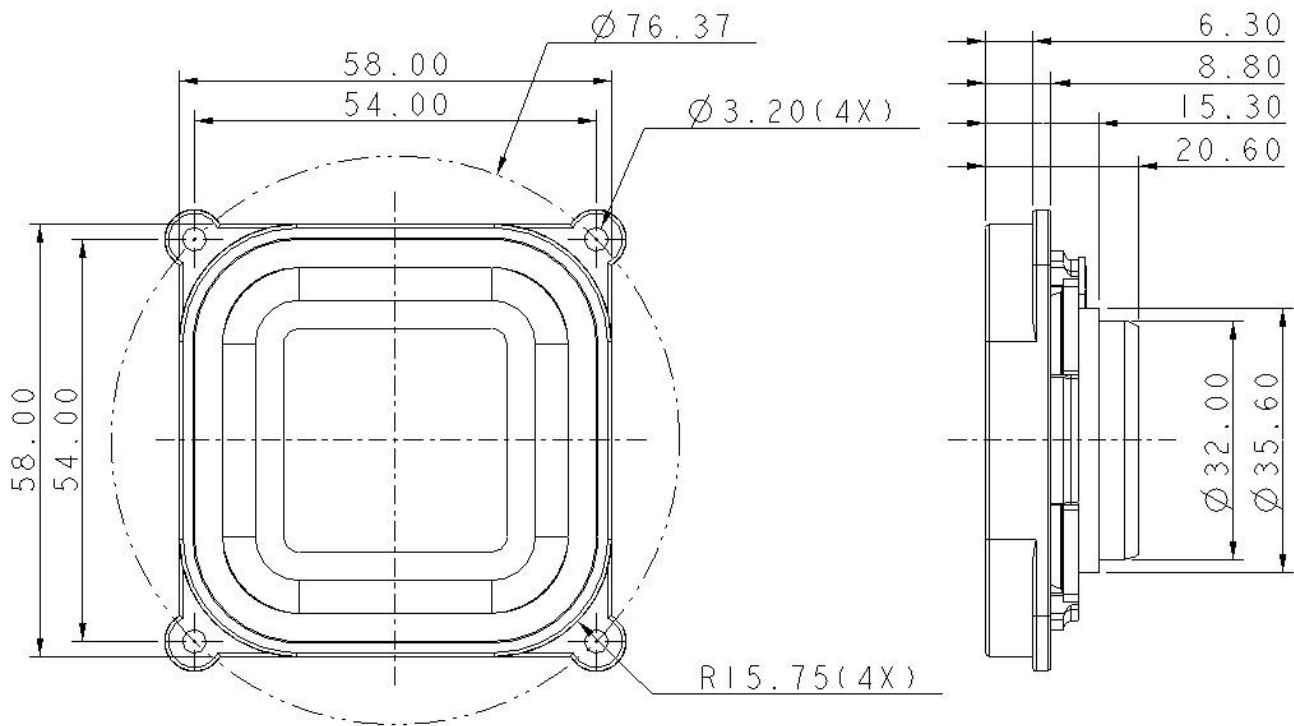

Figure 2. Nominal dimensions