



NEW SCANSPEAK
B 1 3 7 1

**The Newest Build-It-Yourself
Speaker Kit From PBN Audio**

This latest in the coveted line of speaker kits from PBN Audio is already making waves within the audiophile community – and rightly so. Featuring three superlative drivers from ScanSpeak, an international leader in the realm of high-end sound systems, these elegantly simple and lustrously gorgeous speakers define the most basic premise of stereophonic excellence: *It's all about what you hear.* PBN Audio has devoted decades of engineering prowess to designing systems that completely serve the music. The B1371 delivers on that promise, with highly attractive pricing. Everything is included, along with full instructions and tech support.

The B1371 cabinet features genuine walnut veneer, and is hand-finished with PBN's exclusive LiquidVelvet™ finish. Each speaker comes with a fabric grille (below) which snaps on or off in seconds.

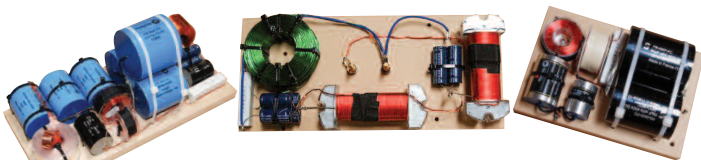

Recommended internal crossover parts if bought separately. For those wishing to build their own cabinets, these drivers and crossovers can be purchased through www.madisound.com for **\$3,350**.

If you prefer, a completed pair of assembled and tested speakers is available through PBN for **\$9,500**.

Price does not include shipping costs, which will vary.



ScanSpeak Drivers: D2908/714000 high-power 8 ohm 1" beryllium dome tweeter; the Revelator 18M/4631T00 midrange with sliced paper cone technology and patented Symmetrical Drive; and the Revelator 32W/4878T01, a powerful woofer with 3" voice coil and low resonance frequency. It features an exclusive new paper-sandwich cone with a special foam filling technology.



SCANSPEAK B1371

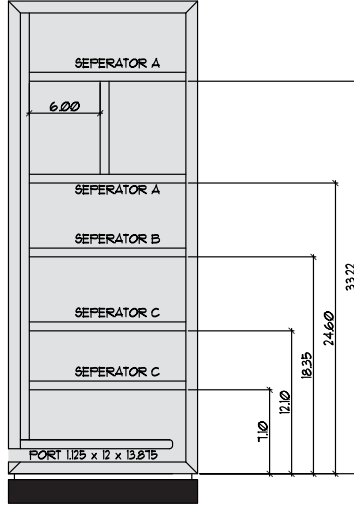

SIDE VIEW

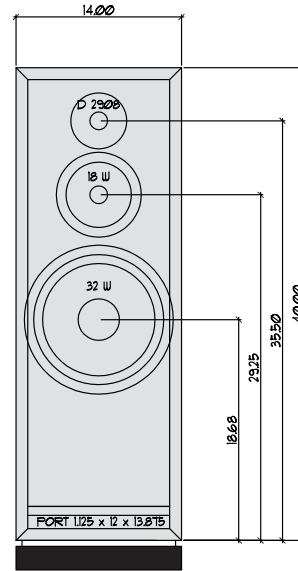

FRONT VIEW

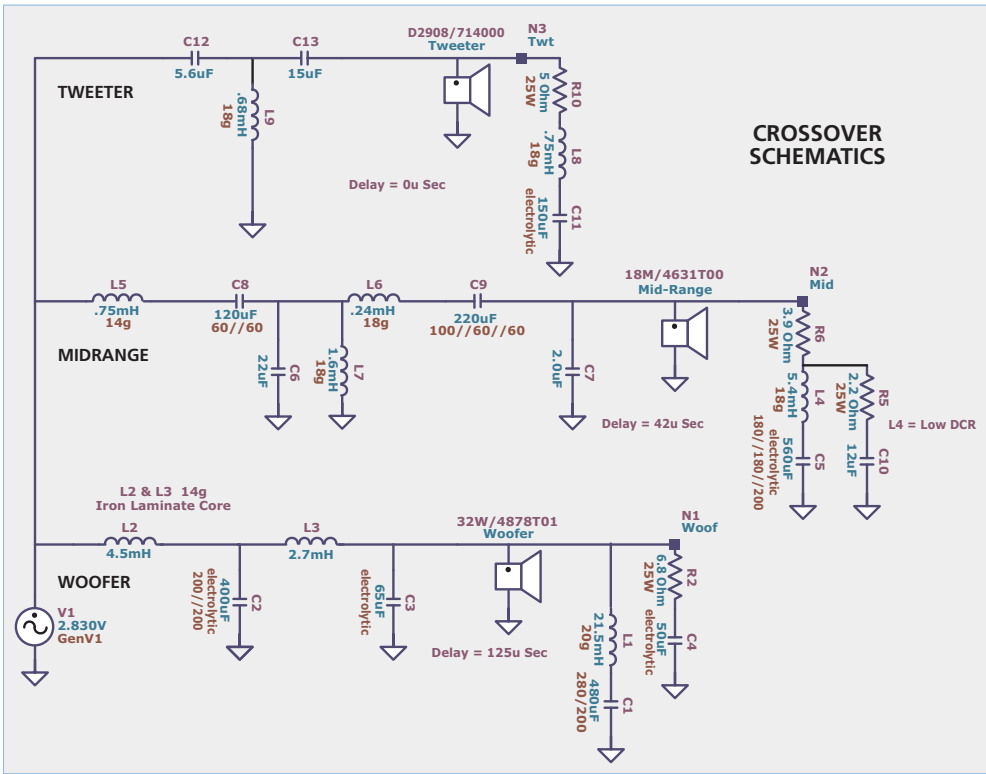
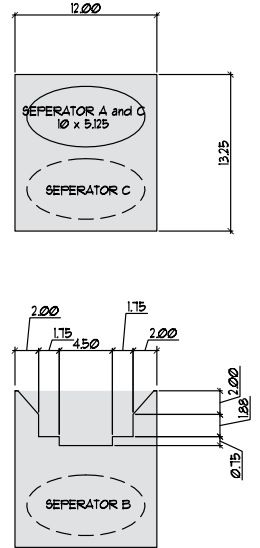

B1371 TECHNICAL SPECIFICATIONS

Driver Compliment:
LF = 13" MF = 7" HF = 1"

Efficiency:
93dB/2.83V @ 1 meter

Frequency response :
30Hz to 40kHz @ -6dB +3dB 50Hz - 12kHz @ +/- 1dB

Impedance:
Nominal 4 Ohm (min 2.9 Ohm @ 400 Hz)
Max 15 Ohm @ 3.5kHz

Electrical Phase angle:
Max +30 Degrees Min -15 Degrees

Crossover Points:
220Hz and 2200Hz

Cabinet Dimensions:
42.5" H x 16" D x 14" W

Net Weight:
140 lbs.

